

INTRODUCTION TO TRIGONOMETRY AND ITS APPLICATIONS

(A) Main Concepts and Results

- Trigonometric Ratios of the angle A in a triangle ABC right angled at B are defined as:

$$\text{sine of } \angle A = \sin A = \frac{\text{side opposite to } \angle A}{\text{hypotenuse}} = \frac{BC}{AC}$$

$$\text{cosine of } \angle A = \cos A = \frac{\text{side adjacent to } \angle A}{\text{hypotenuse}} = \frac{AB}{AC}$$

$$\text{tangent of } \angle A = \tan A = \frac{\text{side opposite to } \angle A}{\text{side adjacent to angle } \angle A} = \frac{BC}{AB}$$

$$\text{cosecant of } \angle A = \operatorname{cosec} A = \frac{1}{\sin A} = \frac{AC}{BC}$$

$$\text{secant of } \angle A = \sec A = \frac{1}{\cos A} = \frac{AC}{AB}$$

$$\text{cotangent of } \angle A = \cot A = \frac{1}{\tan A} = \frac{AB}{BC}$$

$$\tan A = \frac{\sin A}{\cos A}, \cot A = \frac{\cos A}{\sin A}$$

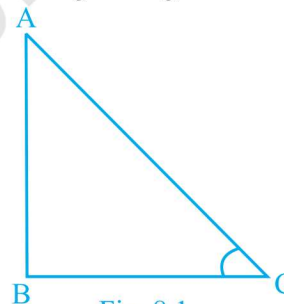

Fig. 8.1

- The values of trigonometric ratios of an angle do not vary with the lengths of the sides of the triangle, if the angle remains the same.
- If one trigonometric ratio of an angle is given, the other trigonometric ratios of the angle can be determined.
- Trigonometric ratios of angles: 0° , 30° , 45° , 60° and 90° .

A	0°	30°	45°	60°	90°
sin A	0	$\frac{1}{2}$	$\frac{1}{\sqrt{2}}$	$\frac{\sqrt{3}}{2}$	1
cos A	1	$\frac{\sqrt{3}}{2}$	$\frac{1}{\sqrt{2}}$	$\frac{1}{2}$	0
tan A	0	$\frac{1}{\sqrt{3}}$	1	$\sqrt{3}$	Not defined
cosec A	Not defined	2	$\sqrt{2}$	$\frac{2}{\sqrt{3}}$	1
sec A	1	$\frac{2}{\sqrt{3}}$	$\sqrt{2}$	2	Not defined
cot A	Not defined	$\sqrt{3}$	1	$\frac{1}{\sqrt{3}}$	0

- The value of sin A or cos A never exceeds 1, whereas the value of sec A or cosec A is always greater than or equal to 1.
- Trigonometric ratios of complementary angles:
 $\sin(90^\circ - A) = \cos A$, $\cos(90^\circ - A) = \sin A$
 $\tan(90^\circ - A) = \cot A$, $\cot(90^\circ - A) = \tan A$
 $\sec(90^\circ - A) = \csc A$, $\csc(90^\circ - A) = \sec A$
- Trigonometric identities:
 $\cos^2 A + \sin^2 A = 1$
 $1 + \tan^2 A = \sec^2 A$
 $\cot^2 A + 1 = \csc^2 A$

- The ‘line of sight’ is the line from the eye of an observer to the point in the object viewed by the observer.
- The ‘angle of elevation’ of an object viewed, is the angle formed by the line of sight with the horizontal when it is above the horizontal level.
- The angle of depression of an object viewed, is the angle formed by the line of sight with the horizontal when it is below the horizontal level.
- The height or length of an object or the distance between two distinct objects can be determined with the help of trigonometric ratios.

(B) Multiple Choice Questions

Choose the correct answer from the given four options:

Sample Question 1 : The value of $(\sin 30^\circ + \cos 30^\circ) - (\sin 60^\circ + \cos 60^\circ)$ is

- (A) -1 (B) 0 (C) 1 (D) 2

Solution : Answer (B)

Sample Question 2 : The value of $\frac{\tan 30^\circ}{\cot 60^\circ}$ is

- (A) $\frac{1}{\sqrt{2}}$ (B) $\frac{1}{\sqrt{3}}$ (C) $\sqrt{3}$ (D) 1

Solution : Answer (D)

Sample Question 3 : The value of $(\sin 45^\circ + \cos 45^\circ)$ is

- (A) $\frac{1}{\sqrt{2}}$ (B) $\sqrt{2}$ (C) $\frac{\sqrt{3}}{2}$ (D) 1

Solution : Answer (B)

EXERCISE 8.1

Choose the correct answer from the given four options:

1. If $\cos A = \frac{4}{5}$, then the value of $\tan A$ is

- (A) $\frac{3}{5}$ (B) $\frac{3}{4}$ (C) $\frac{4}{3}$ (D) $\frac{5}{3}$

2. If $\sin A = \frac{1}{2}$, then the value of $\cot A$ is
- (A) $\sqrt{3}$ (B) $\frac{1}{\sqrt{3}}$ (C) $\frac{\sqrt{3}}{2}$ (D) 1
3. The value of the expression $[\operatorname{cosec}(75^\circ + \theta) - \sec(15^\circ - \theta) - \tan(55^\circ + \theta) + \cot(35^\circ - \theta)]$ is
- (A) -1 (B) 0 (C) 1 (D) $\frac{3}{2}$
4. Given that $\sin\theta = \frac{a}{b}$, then $\cos\theta$ is equal to
- (A) $\frac{b}{\sqrt{b^2 - a^2}}$ (B) $\frac{b}{a}$ (C) $\frac{\sqrt{b^2 - a^2}}{b}$ (D) $\frac{a}{\sqrt{b^2 - a^2}}$
5. If $\cos(\alpha + \beta) = 0$, then $\sin(\alpha - \beta)$ can be reduced to
- (A) $\cos\beta$ (B) $\cos 2\beta$ (C) $\sin\alpha$ (D) $\sin 2\alpha$
6. The value of $(\tan 1^\circ \tan 2^\circ \tan 3^\circ \dots \tan 89^\circ)$ is
- (A) 0 (B) 1 (C) 2 (D) $\frac{1}{2}$
7. If $\cos 9\alpha = \sin\alpha$ and $9\alpha < 90^\circ$, then the value of $\tan 5\alpha$ is
- (A) $\frac{1}{\sqrt{3}}$ (B) $\sqrt{3}$ (C) 1 (D) 0
8. If ΔABC is right angled at C, then the value of $\cos(A+B)$ is
- (A) 0 (B) 1 (C) $\frac{1}{2}$ (D) $\frac{\sqrt{3}}{2}$
9. If $\sin A + \sin^2 A = 1$, then the value of the expression $(\cos^2 A + \cos^4 A)$ is
- (A) 1 (B) $\frac{1}{2}$ (C) 2 (D) 3
10. Given that $\sin\alpha = \frac{1}{2}$ and $\cos\beta = \frac{1}{2}$, then the value of $(\alpha + \beta)$ is
- (A) 0° (B) 30° (C) 60° (D) 90°

11. The value of the expression $\left[\frac{\sin^2 22^\circ + \sin^2 68^\circ}{\cos^2 22^\circ + \cos^2 68^\circ} + \sin^2 63^\circ + \cos 63^\circ \sin 27^\circ \right]$ is
- (A) 3 (B) 2 (C) 1 (D) 0

12. If $4 \tan \theta = 3$, then $\left(\frac{4 \sin \theta - \cos \theta}{4 \sin \theta + \cos \theta} \right)$ is equal to

- (A) $\frac{2}{3}$ (B) $\frac{1}{3}$ (C) $\frac{1}{2}$ (D) $\frac{3}{4}$

13. If $\sin \theta - \cos \theta = 0$, then the value of $(\sin^4 \theta + \cos^4 \theta)$ is

- (A) 1 (B) $\frac{3}{4}$ (C) $\frac{1}{2}$ (D) $\frac{1}{4}$

14. $\sin (45^\circ + \theta) - \cos (45^\circ - \theta)$ is equal to

- (A) $2 \cos \theta$ (B) 0 (C) $2 \sin \theta$ (D) 1

15. A pole 6 m high casts a shadow $2\sqrt{3}$ m long on the ground, then the Sun's elevation is

- (A) 60° (B) 45° (C) 30° (D) 90°

(C) Short Answer Questions with Reasoning

Write 'True' or 'False' and justify your answer.

Sample Question 1 : The value of $\sin \theta + \cos \theta$ is always greater than 1.

Solution : False.

The value of $(\sin \theta + \cos \theta)$ for $\theta = 0^\circ$ is 1.

Sample Question 2 : The value of $\tan \theta$ ($\theta < 90^\circ$) increases as θ increases.

Solution : True.

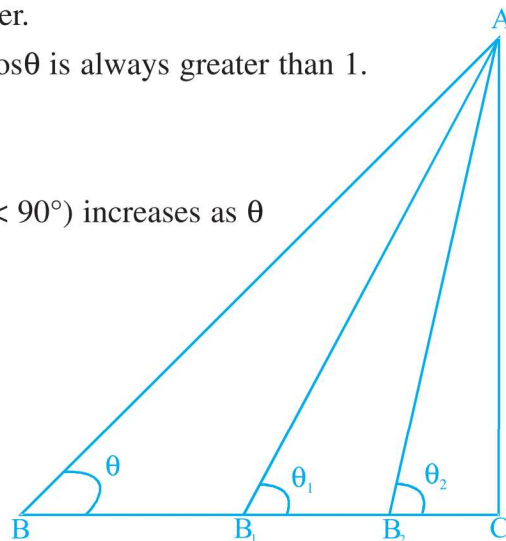

Fig. 8.2

In Fig. 8.2, B is moved closer to C along BC. It is observed that

- (i) θ increases (as $\theta_1 > \theta$, $\theta_2 > \theta_1$, ...)
- (ii) BC decreases ($B_1C < BC$, $B_2C < B_1C$, ...)

Thus the perpendicular AC remains fixed and the base BC decreases. Hence $\tan\theta$ increases as θ increases.

Sample Question 3 : $\tan\theta$ increases faster than $\sin\theta$ as θ increases.

Solution : True

We know that $\sin\theta$ increases as θ increases but $\cos\theta$ decreases as θ increases.

We have $\tan\theta = \frac{\sin\theta}{\cos\theta}$

Now as θ increases, $\sin\theta$ increases but $\cos\theta$ decreases. Therefore, in case of $\tan\theta$, the numerator increases and the denominator decreases. But in case of $\sin\theta$ which can be

seen as $\frac{\sin\theta}{1}$, only the numerator increases but the denominator remains fixed at 1.

Hence $\tan\theta$ increases faster than $\sin\theta$ as θ increases.

Sample Question 4 : The value of $\sin\theta$ is $a + \frac{1}{a}$, where 'a' is a positive number.

Solution : False.

We know that $\sqrt{a} - \frac{1}{\sqrt{a}} \geq 0$ or $a + \frac{1}{a} \geq 2$, but $\sin\theta$ is not greater than 1.

Alternatively, there exists the following three possibilities :

Case 1. If $a < 1$, then $a + \frac{1}{a} > 1$

Case 2. If $a = 1$, then $a + \frac{1}{a} > 1$

Case 3. If $a > 1$, then $a + \frac{1}{a} > 1$

However, $\sin\theta$ cannot be greater than 1.

EXERCISE 8.2

Write 'True' or 'False' and justify your answer in each of the following:

- $\frac{\tan 47^\circ}{\cot 43^\circ} = 1$
- The value of the expression $(\cos^2 23^\circ - \sin^2 67^\circ)$ is positive.
- The value of the expression $(\sin 80^\circ - \cos 80^\circ)$ is negative.
- $\sqrt{(1 - \cos^2 \theta) \sec^2 \theta} = \tan \theta$
- If $\cos A + \cos^2 A = 1$, then $\sin^2 A + \sin^4 A = 1$.
- $(\tan \theta + 2)(2 \tan \theta + 1) = 5 \tan \theta + \sec^2 \theta$.
- If the length of the shadow of a tower is increasing, then the angle of elevation of the sun is also increasing.
- If a man standing on a platform 3 metres above the surface of a lake observes a cloud and its reflection in the lake, then the angle of elevation of the cloud is equal to the angle of depression of its reflection.
- The value of $2 \sin \theta$ can be $a + \frac{1}{a}$, where a is a positive number, and $a \neq 1$.
- $\cos \theta = \frac{a^2 + b^2}{2ab}$, where a and b are two distinct numbers such that $ab > 0$.
- The angle of elevation of the top of a tower is 30° . If the height of the tower is doubled, then the angle of elevation of its top will also be doubled.
- If the height of a tower and the distance of the point of observation from its foot, both, are increased by 10%, then the angle of elevation of its top remains unchanged.

(D) Short Answer Questions

Sample Question 1 Prove that $\sin^6 \theta + \cos^6 \theta + 3 \sin^2 \theta \cos^2 \theta = 1$

Solution : We know that $\sin^2 \theta + \cos^2 \theta = 1$

Therefore, $(\sin^2 \theta + \cos^2 \theta)^3 = 1$

or, $(\sin^2 \theta)^3 + (\cos^2 \theta)^3 + 3 \sin^2 \theta \cos^2 \theta (\sin^2 \theta + \cos^2 \theta) = 1$

or, $\sin^6 \theta + \cos^6 \theta + 3 \sin^2 \theta \cos^2 \theta = 1$

Sample Question 2 : Prove that $(\sin^4 \theta - \cos^4 \theta + 1) \operatorname{cosec}^2 \theta = 2$

Solution :

$$\begin{aligned}
 \text{L.H.S.} &= (\sin^4\theta - \cos^4\theta + 1) \operatorname{cosec}^2\theta \\
 &= [(\sin^2\theta - \cos^2\theta)(\sin^2\theta + \cos^2\theta) + 1] \operatorname{cosec}^2\theta \\
 &= (\sin^2\theta - \cos^2\theta + 1) \operatorname{cosec}^2\theta \\
 &\qquad\qquad\qquad [\text{Because } \sin^2\theta + \cos^2\theta = 1] \\
 &= 2\sin^2\theta \operatorname{cosec}^2\theta \qquad [\text{Because } 1 - \cos^2\theta = \sin^2\theta] \\
 &= 2 = \text{RHS}
 \end{aligned}$$

Sample Question 3 : Given that $\alpha + \beta = 90^\circ$, show that

$$\sqrt{\cos \alpha \operatorname{cosec} \beta - \cos \alpha \sin \beta} = \sin \alpha$$

Solution :

$$\begin{aligned}
 \sqrt{\cos \alpha \operatorname{cosec} \beta - \cos \alpha \sin \beta} &= \sqrt{\cos \alpha \operatorname{cosec} (90^\circ - \alpha) - \cos \alpha \sin (90^\circ - \alpha)} \\
 &\qquad\qquad\qquad [\text{Given } \alpha + \beta = 90^\circ] \\
 &= \sqrt{\cos \alpha \sec \alpha - \cos \alpha \cos \alpha} \\
 &= \sqrt{1 - \cos^2 \alpha} \\
 &= \sin \alpha
 \end{aligned}$$

Sample Question 4 : If $\sin \theta + \cos \theta = \sqrt{3}$, then prove that $\tan \theta + \cot \theta = 1$

Solution .

$$\begin{aligned}
 \sin \theta + \cos \theta &= \sqrt{3} && \text{(Given)} \\
 \text{or} & (\sin \theta + \cos \theta)^2 = 3 \\
 \text{or} & \sin^2 \theta + \cos^2 \theta + 2\sin \theta \cos \theta = 3 \\
 & 2\sin \theta \cos \theta = 2 && [\sin^2 \theta + \cos^2 \theta = 1] \\
 \text{or} & \sin \theta \cos \theta = 1 = \sin^2 \theta + \cos^2 \theta \\
 \text{or} & 1 = \frac{\sin^2 \theta + \cos^2 \theta}{\sin \theta \cos \theta}
 \end{aligned}$$

Therefore, $\tan \theta + \cot \theta = 1$

EXERCISE 8.3

Prove the following (from Q.1 to Q.7):

$$1. \quad \frac{\sin \theta}{1 + \cos \theta} + \frac{1 + \cos \theta}{\sin \theta} = 2 \operatorname{cosec} \theta$$

$$2. \quad \frac{\tan A}{1 + \sec A} - \frac{\tan A}{1 - \sec A} = 2 \operatorname{cosec} A$$

$$3. \quad \text{If } \tan A = \frac{3}{4}, \text{ then } \sin A \cos A = \frac{12}{25}$$

$$4. \quad (\sin \alpha + \cos \alpha) (\tan \alpha + \cot \alpha) = \sec \alpha + \operatorname{cosec} \alpha$$

$$5. \quad (\sqrt{3} + 1) (3 - \cot 30^\circ) = \tan^3 60^\circ - 2 \sin 60^\circ$$

$$6. \quad 1 + \frac{\cot^2 \alpha}{1 + \operatorname{cosec} \alpha} = \operatorname{cosec} \alpha$$

$$7. \quad \tan \theta + \tan (90^\circ - \theta) = \sec \theta \sec (90^\circ - \theta)$$

8. Find the angle of elevation of the sun when the shadow of a pole h metres high is $\sqrt{3} h$ metres long.

9. If $\sqrt{3} \tan \theta = 1$, then find the value of $\sin^2 \theta - \cos^2 \theta$.

10. A ladder 15 metres long just reaches the top of a vertical wall. If the ladder makes an angle of 60° with the wall, find the height of the wall.

11. Simplify $(1 + \tan^2 \theta) (1 - \sin \theta) (1 + \sin \theta)$

12. If $2 \sin^2 \theta - \cos^2 \theta = 2$, then find the value of θ .

$$13. \quad \text{Show that } \frac{\cos^2 (45^\circ + \theta) + \cos^2 (45^\circ - \theta)}{\tan (60^\circ + \theta) \tan (30^\circ - \theta)} = 1$$

14. An observer 1.5 metres tall is 20.5 metres away from a tower 22 metres high. Determine the angle of elevation of the top of the tower from the eye of the observer.

15. Show that $\tan^4 \theta + \tan^2 \theta = \sec^4 \theta - \sec^2 \theta$.

(E) Long Answer Questions

Sample Question 1 : A spherical balloon of radius r subtends an angle θ at the eye of an observer. If the angle of elevation of its centre is ϕ , find the height of the centre of the balloon.

Solution : In Fig. 8.3, O is the centre of balloon, whose radius $OP = r$ and $\angle PAQ = \theta$. Also, $\angle OAB = \phi$.

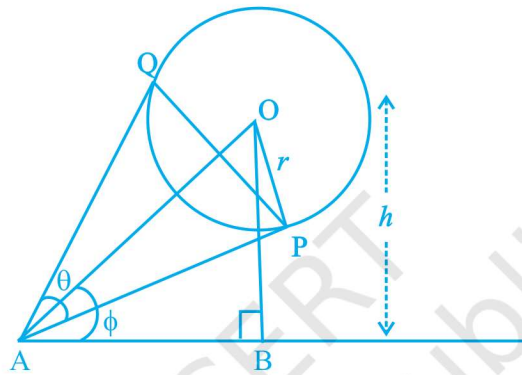

Fig. 8.3

Let the height of the centre of the balloon be h . Thus $OB = h$.

Now, from $\triangle OAP$, $\sin \frac{\theta}{2} = \frac{r}{d}$, where $OA = d$ (1)

Also from $\triangle OAB$, $\sin \phi = \frac{h}{d}$. (2)

From (1) and (2), we get $\frac{\sin \phi}{\sin \frac{\theta}{2}} = \frac{\frac{h}{d}}{\frac{r}{d}} = \frac{h}{r}$

or $h = r \sin \phi \operatorname{cosec} \frac{\theta}{2}$.

Sample Question 2 : From a balloon vertically above a straight road, the angles of depression of two cars at an instant are found to be 45° and 60° . If the cars are 100 m apart, find the height of the balloon.

Solution : Let the height of the balloon at P be h meters (see Fig. 8.4). Let A and B be the two cars. Thus $AB = 100$ m. From ΔPAQ , $AQ = PQ = h$

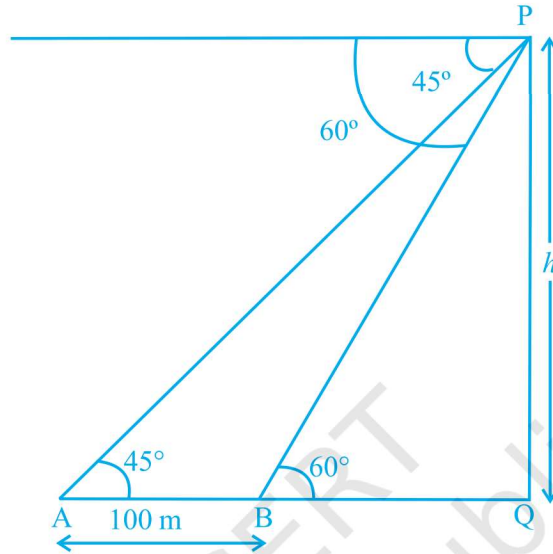

Fig. 8.4

Now from ΔPBQ , $\frac{PQ}{BQ} = \tan 60^\circ = \sqrt{3}$ or $\frac{h}{h-100} = \sqrt{3}$

or $h = \sqrt{3}(h-100)$

Therefore, $h = \frac{100\sqrt{3}}{\sqrt{3}-1} = 50(3 + \sqrt{3})$

i.e., the height of the balloon is $50(3 + \sqrt{3})$ m.

Sample Question 3 : The angle of elevation of a cloud from a point h metres above the surface of a lake is θ and the angle of depression of its reflection in the lake is ϕ .

Prove that the height of the cloud above the lake is $h \left(\frac{\tan \phi + \tan \theta}{\tan \phi - \tan \theta} \right)$.

Solution : Let P be the cloud and Q be its reflection in the lake (see Fig. 8.5). Let A be the point of observation such that $AB = h$.

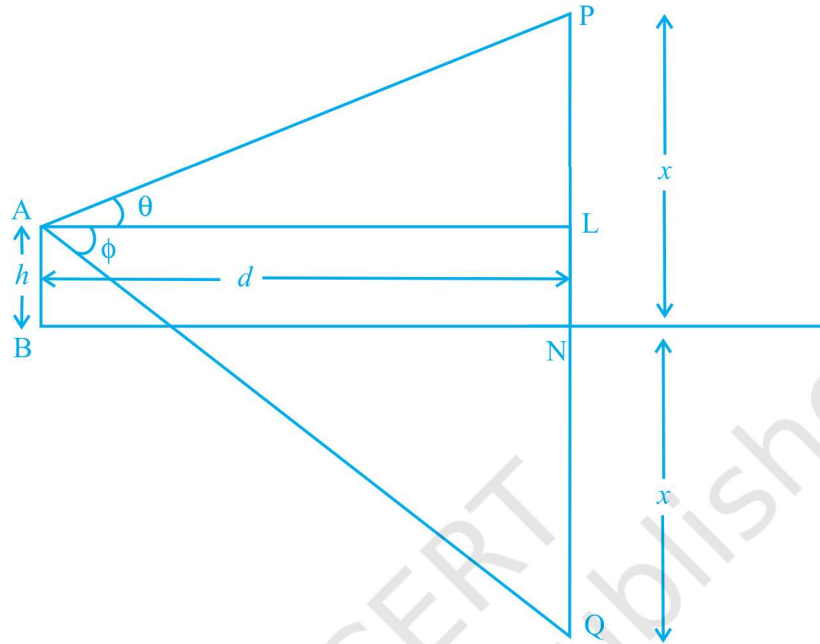

Fig. 8.5

Let the height of the cloud above the lake be x . Let $AL = d$.

$$\text{Now from } \triangle PAL, \frac{x-h}{d} = \tan \theta \quad (1)$$

$$\text{From } \triangle QAL, \frac{x+h}{d} = \tan \phi \quad (2)$$

From (1) and (2), we get

$$\frac{x+h}{x-h} = \frac{\tan \phi}{\tan \theta}$$

$$\text{or } \frac{2x}{2h} = \frac{\tan \phi + \tan \theta}{\tan \phi - \tan \theta}$$

$$\text{Therefore, } x = h \left(\frac{\tan \phi + \tan \theta}{\tan \phi - \tan \theta} \right).$$

EXERCISE 8.4

1. If $\operatorname{cosec}\theta + \cot\theta = p$, then prove that $\cos\theta = \frac{p^2 - 1}{p^2 + 1}$.
2. Prove that $\sqrt{\sec^2\theta + \operatorname{cosec}^2\theta} = \tan\theta + \cot\theta$
3. The angle of elevation of the top of a tower from certain point is 30° . If the observer moves 20 metres towards the tower, the angle of elevation of the top increases by 15° . Find the height of the tower.
4. If $1 + \sin^2\theta = 3\sin\theta \cos\theta$, then prove that $\tan\theta = 1$ or $\frac{1}{2}$.
5. Given that $\sin\theta + 2\cos\theta = 1$, then prove that $2\sin\theta - \cos\theta = 2$.
6. The angle of elevation of the top of a tower from two points distant s and t from its foot are complementary. Prove that the height of the tower is \sqrt{st} .
7. The shadow of a tower standing on a level plane is found to be 50 m longer when Sun's elevation is 30° than when it is 60° . Find the height of the tower.
8. A vertical tower stands on a horizontal plane and is surmounted by a vertical flag staff of height h . At a point on the plane, the angles of elevation of the bottom and the top of the flag staff are α and β , respectively. Prove that the height of the tower is $\left(\frac{h \tan \alpha}{\tan \beta - \tan \alpha}\right)$.
9. If $\tan\theta + \sec\theta = l$, then prove that $\sec\theta = \frac{l^2 + 1}{2l}$.
10. If $\sin\theta + \cos\theta = p$ and $\sec\theta + \operatorname{cosec}\theta = q$, then prove that $q(p^2 - 1) = 2p$.
11. If $a \sin\theta + b \cos\theta = c$, then prove that $a \cos\theta - b \sin\theta = \sqrt{a^2 + b^2 - c^2}$.
12. Prove that $\frac{1 + \sec\theta - \tan\theta}{1 + \sec\theta + \tan\theta} = \frac{1 - \sin\theta}{\cos\theta}$
13. The angle of elevation of the top of a tower 30 m high from the foot of another tower in the same plane is 60° and the angle of elevation of the top of the second tower from the foot of the first tower is 30° . Find the distance between the two towers and also the height of the other tower.

14. From the top of a tower h m high, the angles of depression of two objects, which are in line with the foot of the tower are α and β ($\beta > \alpha$). Find the distance between the two objects.
15. A ladder rests against a vertical wall at an inclination α to the horizontal. Its foot is pulled away from the wall through a distance p so that its upper end slides a distance q down the wall and then the ladder makes an angle β to the horizontal.

Show that
$$\frac{p}{q} = \frac{\cos \beta - \cos \alpha}{\sin \alpha - \sin \beta}.$$

16. The angle of elevation of the top of a vertical tower from a point on the ground is 60° . From another point 10 m vertically above the first, its angle of elevation is 45° . Find the height of the tower.
17. A window of a house is h metres above the ground. From the window, the angles of elevation and depression of the top and the bottom of another house situated on the opposite side of the lane are found to be α and β , respectively. Prove that the height of the other house is $h (1 + \tan \alpha \cot \beta)$ metres.
18. The lower window of a house is at a height of 2 m above the ground and its upper window is 4 m vertically above the lower window. At certain instant the angles of elevation of a balloon from these windows are observed to be 60° and 30° , respectively. Find the height of the balloon above the ground.